

Product datasheet

Specifications



Modicon TM3 - 2 analog or temperature inputs, 1 analog output (screw) 24Vdc

TM3TM3

EAN Code: 3606480649042

Main

Range of product	Modicon TM3
Product or component type	Input/output analog module
Range compatibility	Modicon M221 Modicon M241 Modicon M251 Modicon M262
Analogue input number	2
Analogue input type	current 4...20 mA current 0...20 mA voltage 0...10 V voltage - 10...10 V thermocouple - 200...1000 °C with thermocouple J thermocouple - 200...1300 °C with thermocouple K thermocouple 0...1760 °C with thermocouple R thermocouple 0...1760 °C with thermocouple S thermocouple 0...1820 °C with thermocouple B thermocouple - 200...400 °C with thermocouple T thermocouple - 200...1300 °C with thermocouple N thermocouple - 200...800 °C with thermocouple E thermocouple 0...2315 °C with thermocouple C Ni 100/Ni 1000 temperature probe - 60...180 °C Pt 100 temperature probe - 200...850 °C Pt 1000 temperature probe - 200...600 °C
Analogue output number	1
Analogue output type	Current: 4...20 mA Current: 0...20 mA Voltage: 0...10 V Voltage: - 10...10 V

Complementary

Analogue input resolution	16 bits 15 bits + sign
Permissible continuous overload	13 V, analogue input type: voltage 40 mA, analogue input type: current
Input impedance	<= 50 Ohm current >= 1 MOhm voltage >= 1 MOhm thermocouple >= 1 MOhm temperature probe
Analogue output resolution	12 bits

Disclaimer: This documentation is not intended as a substitute for and is not to be used for determining suitability or reliability of these products for specific user applications

LSB value	0.15 mV 0...10 Vvoltage 0.30 mV - 10...10 Vvoltage 0.30 µA 0...20 mAcurrent 0.244 µA 4...20 mAcurrent 0.1 °Ctemperature probe 0.1 °Cthermocouple 2.44 mV 0...10 V voltage 4.88 mV - 10...10 V voltage 4.88 µA 0...20 mA current 3.91 µA 4...20 mA current
Load type	Resistive
Load impedance ohmic	1 kOhm voltage 300 Ohm current
Stabilisation time	1 ms
Conversion time	100 ms + 100 ms per channel + 1 controller cycle time for analogue input thermocouple 100 ms + 100 ms per channel + 1 controller cycle time for analogue input temperature probe 10 ms + 10 ms per channel + 1 controller cycle time for analogue input voltage/ current
Sampling duration	10 ms, analogue input type: voltage/current 100 ms, analogue input type: voltage/current 100 ms, analogue input type: thermocouple 100 ms, analogue input type: temperature probe
Absolute accuracy error	+/- 6 °C at 25 °C for thermocouple R, S 0...200 °C +/- 0.4 % of full scale at 25 °C for thermocouple K - 200...0 °C +/- 0.4 % of full scale at 25 °C for thermocouple J - 200...0 °C +/- 0.4 % of full scale at 25 °C for thermocouple E - 200...0 °C +/- 0.4 % of full scale at 25 °C for thermocouple T - 200...0 °C +/- 0.4 % of full scale at 25 °C for thermocouple N - 200...0 °C +/- 0.1 % of full scale at 25 °C for analogue input voltage/current +/- 0.1 % of full scale at 25 °C for thermocouple C 0...2315 °C +/- 0.1 % of full scale at 25 °C for Pt 100/Pt 1000, Ni 100/ Ni 1000 temperature probe +/- 0.1 % of full scale at 25 °C for thermocouple R, S 200...1760 °C +/- 0.1 % of full scale at 25 °C for thermocouple B 300...1820 °C +/- 0.1 % of full scale at 25 °C for thermocouple K 0...1300 °C +/- 0.1 % of full scale at 25 °C for thermocouple J 0...1000 °C +/- 0.1 % of full scale at 25 °C for thermocouple E 0...800 °C +/- 0.1 % of full scale at 25 °C for thermocouple T 0...400 °C +/- 0.1 % of full scale at 25 °C for thermocouple N 0...1300 °C +/- 0.1 % of full scale at 25 °C for analogue output voltage/current
Temperature drift	+/- 0.006 %FS/°C
Repeat accuracy	+/-0.5 %FS for input +/- 0.4 %FS for output
Non-linearity	+/- 0.01 %FS, analogue output type: analog output +/- 0.1 %FS, analogue input type: analog input
Output ripple	20 mV
Cross talk	<= 1 LSB
[Us] rated supply voltage	24 V DC
Supply voltage limits	20.4...28.8 V
Type of cable	Twisted shielded pairs cable <30 m for input/output circuit
Current consumption	55 mA at 24 V DC via external supply no load 55 mA at 5 V DC via bus connector no load 60 mA at 5 V DC via bus connector full load 80 mA at 24 V DC via external supply full load
Local signalling	1 LED (green) for PWR
Electrical connection	11 x 2.5 mm ² removable screw terminal block with pitch 5.08 mm adjustment for inputs, outputs and supply
Insulation	Between input and supply at 1500 V AC Between input and internal logic at 500 V AC Between output and supply at 1500 V AC Between output and internal logic at 500 V AC

Marking	CE
Surge withstand	1 kV power supply common mode conforming to IEC 61000-4-5 0.5 kV power supply differential mode conforming to IEC 61000-4-5 1 kV I/O common mode conforming to IEC 61000-4-5 0.5 kV I/O differential mode conforming to IEC 61000-4-5
Mounting support	Top hat type TH35-15 rail conforming to IEC 60715 Top hat type TH35-7.5 rail conforming to IEC 60715 plate or panel with fixing kit
Height	90 mm
Depth	70 mm
Width	23.6 mm
Net weight	0.115 kg

Environment

Standards	IEC 61131-2
Product certifications	CE UKCA RCM EAC cULus cULus HazLoc
Resistance to electrostatic discharge	8 kV in air conforming to IEC 61000-4-2 4 kV on contact conforming to IEC 61000-4-2
Resistance to electromagnetic fields	10 V/m 80 MHz...1 GHz conforming to IEC 61000-4-3 3 V/m 1.4 GHz...2 GHz conforming to IEC 61000-4-3 1 V/m 2 GHz...3 GHz conforming to IEC 61000-4-3
Resistance to magnetic fields	30 A/m conforming to IEC 61000-4-8
Resistance to fast transients	1 kV (I/O) conforming to IEC 61000-4-4
Resistance to conducted disturbances	10 V 0.15...80 MHz conforming to IEC 61000-4-6 3 V spot frequency (2, 3, 4, 6.2, 8.2, 12.6, 16.5, 18.8, 22, 25 MHz) conforming to Marine specification (LR, ABS, DNV, GL)
Electromagnetic emission	Radiated emissions - test level: 40 dB μ V/m QP class A (10 m) at 30...230 MHz conforming to IEC 55011 Radiated emissions - test level: 47 dB μ V/m QP class A (10 m) at 230...1000 MHz conforming to IEC 55011
Immunity to microbreaks	10 ms
Ambient air temperature for operation	-10...55 °C horizontal installation -10...35 °C vertical installation
Ambient air temperature for storage	-25...70 °C
Relative humidity	10...95 %, without condensation (in operation) 10...95 %, without condensation (in storage)
IP degree of protection	IP20
pollution degree	2
Operating altitude	0...2000 m
Storage altitude	0...3000 m
Vibration resistance	3.5 mm at 5...8.4 Hz on DIN rail 3 gn at 8.4...150 Hz on DIN rail
Shock resistance	15 gn for 11 ms

Packing Units

Unit Type of Package 1	PCE
-------------------------------	-----

Number of Units in Package 1	1
Package 1 Height	7.611 cm
Package 1 Width	10.688 cm
Package 1 Length	12.753 cm
Package 1 Weight	220.0 g
Unit Type of Package 2	S04
Number of Units in Package 2	42
Package 2 Height	30 cm
Package 2 Width	40 cm
Package 2 Length	60 cm
Package 2 Weight	10.421 kg
Unit Type of Package 3	P12
Number of Units in Package 3	504
Package 3 Height	105 cm
Package 3 Width	120 cm
Package 3 Length	80 cm
Package 3 Weight	130 kg

Logistical informations

Country of origin	JP
--------------------------	----

Contractual warranty

Warranty	18 months
-----------------	-----------



Environmental Data

Schneider Electric aims to achieve Net Zero status by 2050 through supply chain partnerships, lower impact materials, and circularity via our ongoing “Use Better, Use Longer, Use Again” campaign to extend product lifetimes and recyclability.

[Environmental Data explained >](#)

[How we assess product sustainability >](#)

Environmental footprint

Carbon footprint (kg.eq.CO2 per CR, Total Life cycle) **99**

Environmental Disclosure [Product Environmental Profile](#)

Use Better

Materials and Substances

Packaging made with recycled cardboard **No**

Packaging without single use plastic **Yes**

[EU RoHS Directive](#) **Pro-active compliance (Product out of EU RoHS legal scope)**

REACH Regulation [REACH Declaration](#)

China RoHS Regulation [China RoHS declaration](#)

PVC free **Yes**

Use Again

Repack and remanufacture

Circularity Profile [End of Life Information](#)

WEEE  **The product must be disposed on European Union markets following specific waste collection and never end up in rubbish bins**

Take-back **No**

Dimensions Drawings

Dimensions

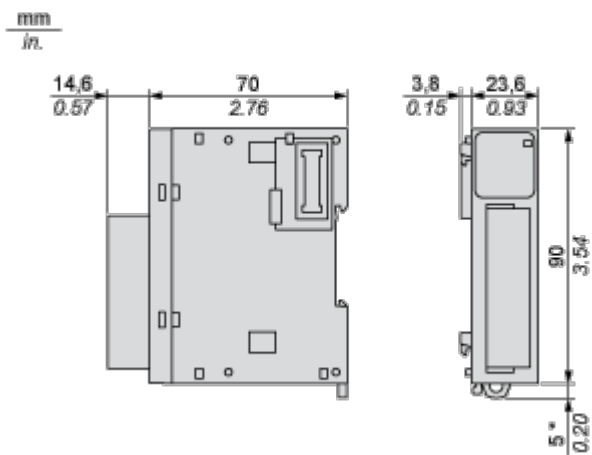

(*) 8.5 mm/0.33 in when the clamp is pulled out.

Mounting and Clearance

Spacing Requirements

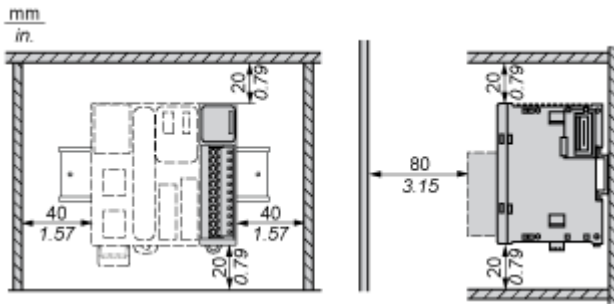

Mounting on a Rail

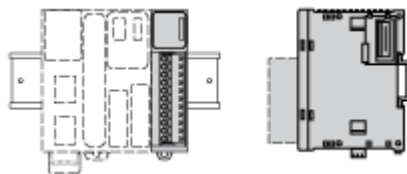

Incorrect Mounting

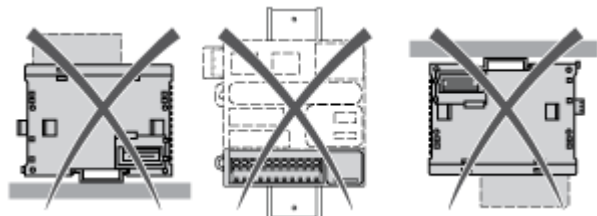

Mounting on a Panel Surface

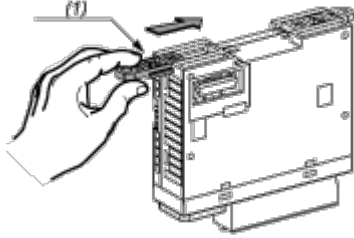

- (1) Install a mounting strip

Mounting Hole Layout

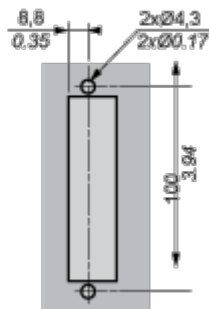
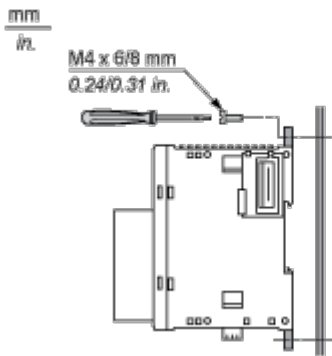

Connections and Schema

Analogue Mixed I/O Module

Wiring Diagram (Current/Voltage type)

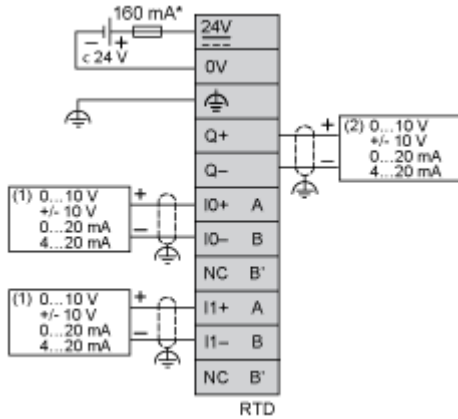

- (*) Type T fuse
- (1) Current/Voltage analog output device
- (2) Current/Voltage analog input device

Wiring Diagram (Thermocouple input type)

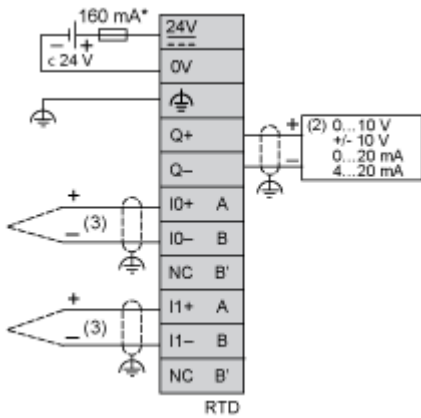

- (*) Type T fuse
- (2) Current/Voltage analog input device
- (3) Thermocouple

Wiring Diagram (Temperature probe input type)

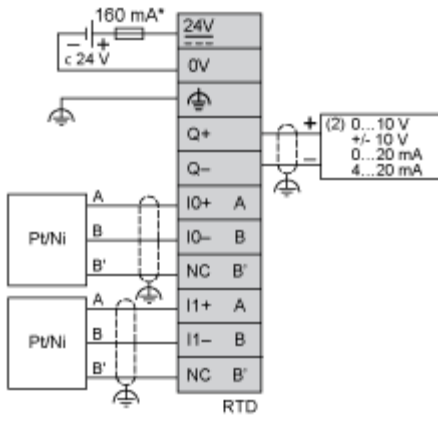

(*) Type T fuse

(2) Current/Voltage analog input device