



### Main

Range of product	Modicon M241
Product or component type	Logic controller
[Us] rated supply voltage	24 V DC
Discrete input number	14 discrete input including 8 fast input conforming to IEC 61131-2 Type 1
Discrete output type	Transistor
Discrete output number	10 transistor including 4 fast output
Discrete output voltage	24 V DC for transistor output
Discrete output current	0.5 A with Q0...Q9 terminal(s) for transistor output 0.1 A with Q0...Q3 terminal(s) for fast output (PTO mode)

### Complementary

Discrete I/O number	24
Number of I/O expansion module	7 (local I/O architecture) 14 (remote I/O architecture)
Supply voltage limits	20.4...28.8 V
Inrush current	$\leq 50$ A
Power consumption in W	32.6...40.4 W with max number of I/O expansion module
Discrete input logic	Sink or source
Discrete input voltage	24 V
Discrete input voltage type	DC
Voltage state 1 guaranteed	$\geq 15$ V for input
Current state 1 guaranteed	$\geq 2.5$ mA for input $\geq 5$ mA for fast input
Voltage state 0 guaranteed	$\leq 5$ V for input
Current state 0 guaranteed	$\leq 1$ mA for input $\leq 1.5$ mA for fast input
Discrete input current	5 mA for input 10.7 mA for fast input
Input impedance	4.7 kOhm for input

	2.81 kOhm for fast input
Response time	50 µs turn-on operation with I0...I13 terminal(s) for input 50 µs turn-off operation with I0...I13 terminal(s) for input <= 2 µs turn-on operation with I0...I7 terminal(s) for fast input <= 2 µs turn-off operation with I0...I7 terminal(s) for fast input <= 34 µs turn-on operation with Q0...Q9 terminal(s) for output <= 250 µs turn-off operation with Q0...Q9 terminal(s) for output <= 2 µs turn-on operation with Q0...Q3 terminal(s) for fast output <= 2 µs turn-off operation with Q0...Q3 terminal(s) for fast output
Configurable filtering time	1 µs for fast input 12 ms for fast input 0 ms for input 1 ms for input 4 ms for input 12 ms for input
Discrete output logic	Positive logic (source)
Output voltage limits	30 V DC
Current per output common	2 A with Q0...Q3 terminal for fast output 2 A with Q4...Q7 terminal for output 1 A with Q8...Q9 terminal for output
Output frequency	<= 20 kHz for fast output (PWM mode) <= 100 kHz for fast output (PLS mode) <= 1 kHz for output
Accuracy	+/- 0.1 % at 20...100 Hz for fast output +/- 1 % at 100 Hz...1 kHz for fast output
Leakage current	<= 5 µA for output
Voltage drop	<= 1 V
Tungsten load	<= 2.4 W
Protection type	Short-circuit and overload protection with automatic reset Reverse polarity protection for fast output Short-circuit protection
Reset time	10 ms automatic reset output 12 s automatic reset fast output
Memory capacity	8 MB for program 64 MB for system memory RAM
Data backed up	128 MB built-in flash memory for backup of user programs
Data storage equipment	<= 32 GB SD card optional
Battery type	BR2032 lithium non-rechargeable, battery life: 4 yr
Backup time	2 years at 25 °C
Execution time for 1 KInstruction	0.3 ms for event and periodic task 0.7 ms for other instruction
Application structure	8 external event tasks 3 cyclic master tasks + 1 freewheeling task 8 event tasks 4 cyclic master tasks
Realtime clock	With
Clock drift	<= 60 s/month at 25 °C
Positioning functions	PWM/PTO function 4 channel(s) (positioning frequency: 100 kHz)
Counting input number	4 fast input (HSC mode)
Control signal type	A/B signal at 100 kHz for fast input (HSC mode) Pulse/Direction signal at 200 kHz for fast input (HSC mode) Single phase signal at 200 kHz for fast input (HSC mode)
Integrated connection type	USB port with connector mini B USB 2.0 Ethernet with connector RJ45 Non isolated serial link "serial 1" with connector RJ45 and interface RS232/RS485 Non isolated serial link "serial 2" with connector removable screw terminal block and interface RS485 CANopen J1939 with connector male SUB-D 9
Supply	Serial link supply "serial 1" at 5 V, 200 mA
Transmission rate	1.2...115.2 kbit/s (115.2 kbit/s by default) for bus length of 15 m - communication protocol: RS485 1.2...115.2 kbit/s (115.2 kbit/s by default) for bus length of 3 m - communication protocol: RS232 480 Mbit/s for bus length of 3 m - communication protocol: USB 10/100 Mbit/s - communication protocol: Ethernet 1000 kbit/s for bus length of 20 m - communication protocol: CANopen 800 kbit/s for bus length of 40 m - communication protocol: CANopen

500 kbit/s for bus length of 100 m - communication protocol: CANopen  
 250 kbit/s for bus length of 250 m - communication protocol: CANopen  
 125 kbit/s for bus length of 500 m - communication protocol: CANopen  
 50 kbit/s for bus length of 1000 m - communication protocol: CANopen  
 20 kbit/s for bus length of 2500 m - communication protocol: CANopen

Communication port protocol	Modbus non isolated serial link with master/slave method
Port Ethernet	1 - 10BASE-T/100BASE-TX port with copper cable support
Communication service	Ethernet/IP adapter DHCP client IEC VAR ACCESS Modbus TCP client Modbus TCP server Modbus TCP slave device SNMP client/server FTP client/server SQL client Send email from the controller based on TCP/UDP library
Local signalling	1 LED green for SD card access (SD) 1 LED red for BAT 1 LED green for SL1 1 LED green for SL2 1 LED per channel green for I/O state 1 LED red for I/O error (I/O) 1 LED red for bus fault on TM4 (TM4) 1 LED green for Ethernet port activity 1 LED green for CANopen run 1 LED green for CANopen error 1 LED red for module error (ERR) 1 LED green for PWR 1 LED green for RUN
Electrical connection	Removable screw terminal block for inputs and outputs (pitch 5.08 mm) Removable screw terminal block for connecting the 24 V DC power supply (pitch 5.08 mm)
Cable length	<= 50 m unshielded cable for input <= 10 m shielded cable for fast input <= 3 m shielded cable for fast output <= 50 m unshielded cable for output
Insulation	500 V AC between fast input and internal logic Non-insulated between inputs 500 V AC between output and internal logic 500 V AC between fast output and internal logic Non-insulated between outputs 500 V AC between input and internal logic 500 V AC between supply and internal logic Non-insulated between supply and ground
Marking	CE
Surge withstand	1 kV for power lines (DC) in common mode conforming to EN/IEC 61000-4-5 1 kV for shielded cable in common mode conforming to EN/IEC 61000-4-5 0.5 kV for power lines (DC) in differential mode conforming to EN/IEC 61000-4-5 1 kV for relay output in differential mode conforming to EN/IEC 61000-4-5 1 kV for input in common mode conforming to EN/IEC 61000-4-5 1 kV for transistor output in common mode conforming to EN/IEC 61000-4-5
Web services	Web server
Maximum number of connections	16 connection(s) for Ethernet/IP device 8 connection(s) for Modbus server
CANopen feature profile	DS 301 V4.02 DR 303-1
Number of slave	<= 63 CANopen
Mounting support	Top hat type TH35-15 rail conforming to IEC 60715 Top hat type TH35-7.5 rail conforming to IEC 60715 Plate or panel with fixing kit
Height	90 mm
Depth	95 mm
Width	150 mm
Product weight	0.53 kg

## Environment

Standards	CSA C22.2 No 142 ANSI/ISA 12-12-01 UL 1604 CSA C22.2 No 213 EN/IEC 61131-2 : 2007 Marine specification (LR, ABS, DNV, GL) UL 508
Product certifications	RCM cULus IACS E10 CSA
Resistance to electrostatic discharge	4 kV on contact conforming to EN/IEC 61000-4-2 8 kV in air conforming to EN/IEC 61000-4-2
Resistance to electromagnetic fields	10 V/m (80 MHz...1 GHz) conforming to EN/IEC 61000-4-3 3 V/m (1.4 GHz...2 GHz) conforming to EN/IEC 61000-4-3 1 V/m (2 GHz...3 GHz) conforming to EN/IEC 61000-4-3
Resistance to fast transients	2 kV for power lines conforming to EN/IEC 61000-4-4 1 kV for Ethernet line conforming to EN/IEC 61000-4-4 1 kV for serial link conforming to EN/IEC 61000-4-4 1 kV for input conforming to EN/IEC 61000-4-4 1 kV for transistor output conforming to EN/IEC 61000-4-4
Resistance to conducted disturbances, induced by radio frequency fields	10 V (0.15...80 MHz) conforming to EN/IEC 61000-4-6 3 V (0.1...80 MHz) conforming to Marine specification (LR, ABS, DNV, GL) 10 V (spot frequency (2, 3, 4, 6.2, 8.2, 12.6, 16.5, 18.8, 22, 25 MHz)) conforming to Marine specification (LR, ABS, DNV, GL)
Electromagnetic emission	Conducted emissions, test level: 120...69 dB $\mu$ V/m QP, condition of test: power lines (radio frequency: 10...150 kHz) conforming to EN/IEC 55011 Conducted emissions, test level: 79...63 dB $\mu$ V/m QP, condition of test: power lines (radio frequency: 150 kHz...1.5 MHz) conforming to EN/IEC 55011 Conducted emissions, test level: 63 dB $\mu$ V/m QP, condition of test: power lines (radio frequency: 1.5...30 MHz) conforming to EN/IEC 55011 Radiated emissions, test level: 40 dB $\mu$ V/m QP with class A (radio frequency: 30...230 MHz) conforming to EN/IEC 55011 Radiated emissions, test level: 47 dB $\mu$ V/m QP with class A (radio frequency: 230 MHz...1 GHz) conforming to EN/IEC 55011
Immunity to microbreaks	10 ms
Ambient air temperature for operation	-10...55 °C for horizontal installation -10...50 °C for vertical installation
Ambient air temperature for storage	-25...70 °C
Relative humidity	10...95 % without condensation in operation 10...95 % without condensation in storage
IP degree of protection	IP20 with protective cover in place
Pollution degree	2
Operating altitude	0...2000 m
Storage altitude	0...3000 m
Vibration resistance	3.5 mm (vibration frequency: 5...8.4 Hz) on symmetrical rail 3 gn (vibration frequency: 8.4...150 Hz) on symmetrical rail 3.5 mm (vibration frequency: 5...8.4 Hz) on panel mounting 3 gn (vibration frequency: 8.4...150 Hz) on panel mounting
Shock resistance	15 gn for 11 ms

## Offer Sustainability

Sustainable offer status	Green Premium product
RoHS (date code: YYWW)	Compliant - since 1330 - Schneider Electric declaration of conformity <a href="#">Schneider Electric declaration of conformity</a>
REACH	Reference not containing SVHC above the threshold <a href="#">Reference not containing SVHC above the threshold</a>
Product environmental profile	Available <a href="#">Product environmental</a>
Product end of life instructions	Available



Dimensions

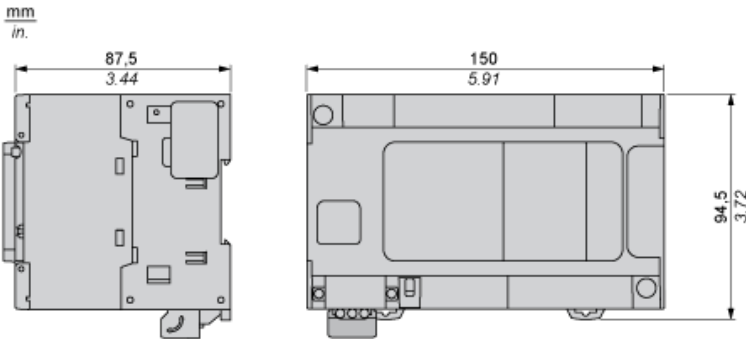

Clearance

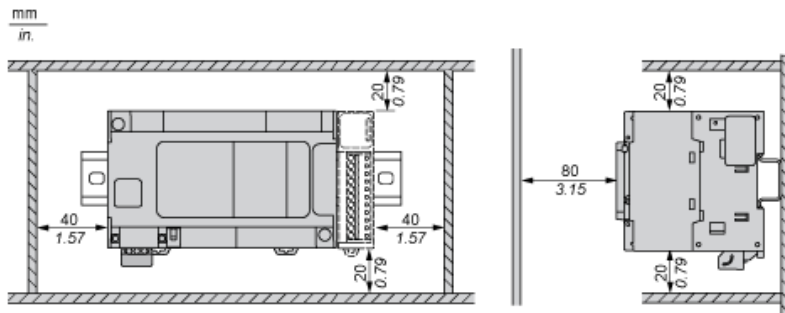

Mounting Position

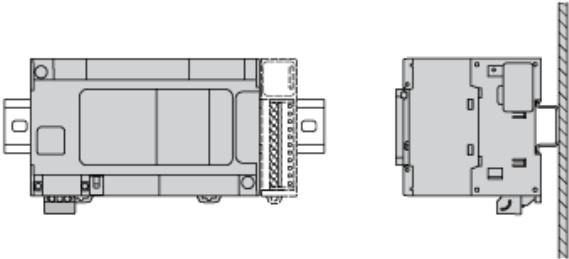

Acceptable Mounting

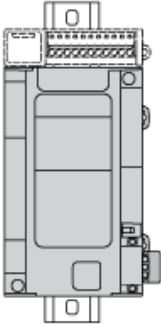

NOTE: Expansion modules must be mounted above the logic controller.

Incorrect Mounting

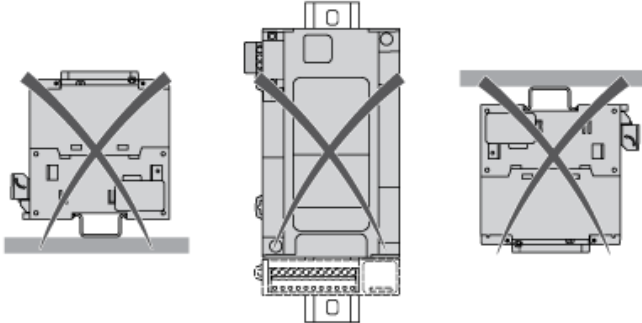

---

Direct Mounting On a Panel Surface

---

Mounting Hole Layout

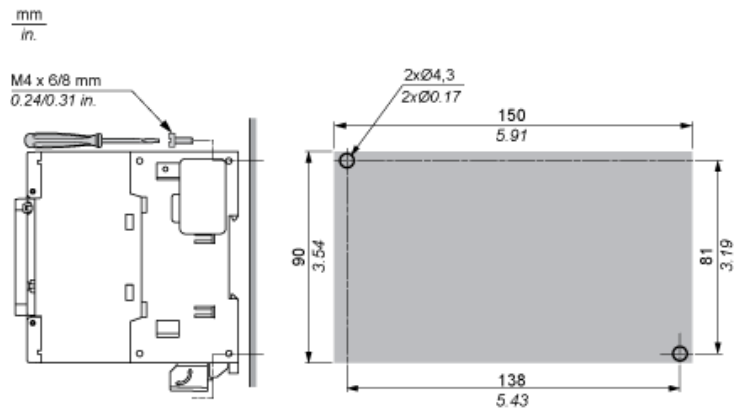

Digital Inputs

Wiring Diagram

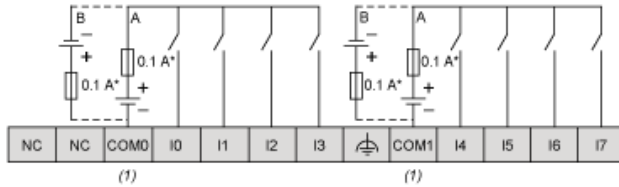

- (\*) : Type T fuse
- (1) : The COM0, COM1 and COM2 terminals are not connected internally
- (A) : Sink wiring (positive logic)
- (B) : Source wiring (negative logic)

Fast Input Wiring (I0...I7)

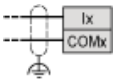

---

Fast Transistor Outputs

---

Wiring Diagram

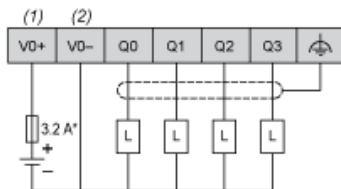

- (\*) : Type T fuse  
(1) The V0+, V1+, V2+ and V3+ terminals are not connected internally.  
(2) The V0-, V1-, V2- and V3- terminals are not connected internally.

---

Transistor Outputs

---

Wiring Diagram

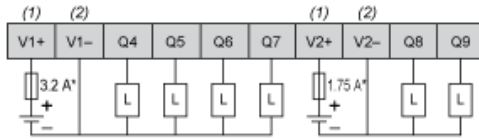

- (\*) : Type T fuse
- (1) : The V1+ and V2+ terminals are not connected internally.
- (2) : The V1- and V2- terminals are not connected internally.

## USB Mini-B Connection

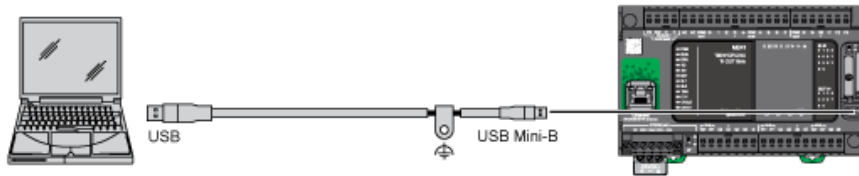

Ethernet Connection to a PC

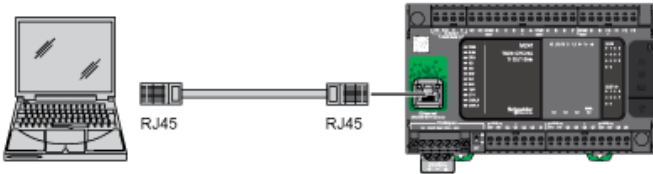

CANopen Connection

Wiring Diagram

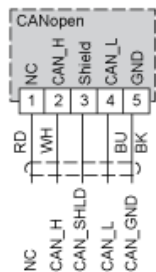

Pin	Signal	Description	Marking	Color of Cable
1	Not used	Reserved	NC	red
2	CAN_H	CAN_H bus line (dominant high)	CAN_H	white
3	CAN_SHLD	Optional CAN shield	Shield	-
4	CAN_L	CAN_L bus line (dominant low)	CAN_L	blue
5	CAN_GND	CAN Ground	GND	black