



Main

Range of product	Magelis GTU
Product or component type	Flat screen
Terminal type	Touchscreen display
Integrated connection type	USB 2.0 type A USB 2.0 type mini B

Complementary

Pixel resolution	1024 x 768
Function available	Brightness sensor
[Us] rated supply voltage	12...24 V DC power supply
Supply voltage limits	10.8...28.8 V
Power consumption in W	22 W
Display size	15 inch
Display type	Colour TFT LCD
Display resolution	1024 x 768 pixels XGA
Display colour	16 million colours
Backlight lifespan	50000 hours
Touch panel	Multi touch analogue resistive
Type of installation	Indoor installation
Type of cooling	Natural convection
Inrush current	30 A
Cut-out dimensions	383.5 (+ 1/- 0) x 282.5 (+ 1/- 0) mm
Width	397 mm
Height	296 mm
Depth	67 mm
Product weight	4.5 kg

Disclaimer: This documentation is not intended as a substitute for and is not to be used for determining suitability or reliability of these products for specific user applications

Environment

IP degree of protection	IP66 (front panel) IP67 (front panel)
NEMA degree of protection	NEMA 4X (front panel)
Standards	CSA C22.2 No 142 ANSI/ISA 12-12-01 IEC 61132-2 CSA C22.2 No 213 : class I division 2 UL 508
Product certifications	RCM cULus CE KC
Ambient air temperature for operation	0...60 °C conforming to EN 61131-2
Ambient air temperature for storage	-20...60 °C
Pollution degree	2
Relative humidity	10...90 % (non-condensing)
Operating altitude	2000 m
Vibration resistance	3.5 mm constant amplitude (f = 5...9 Hz) conforming to EN/IEC 61131-2 9.8 m/s ² (f = 9...150 Hz) conforming to EN/IEC 61131-2
Shock resistance	147 m/s ² conforming to EN/IEC 61131-2
Electromagnetic compatibility	Electrostatic discharge immunity test, level 3 conforming to EN/IEC 61000-4-2

Offer Sustainability

Sustainable offer status	Green Premium product
RoHS (date code: YYWW)	Compliant - since 1347 - Schneider Electric declaration of conformity Schneider Electric declaration of conformity
REACH	Reference not containing SVHC above the threshold Reference not containing SVHC above the threshold
Product environmental profile	Available Product environmental
Product end of life instructions	Available End of life manual

Contractual warranty

Warranty period	18 months
-----------------	-----------

External Dimensions

Display Unit with Box Module

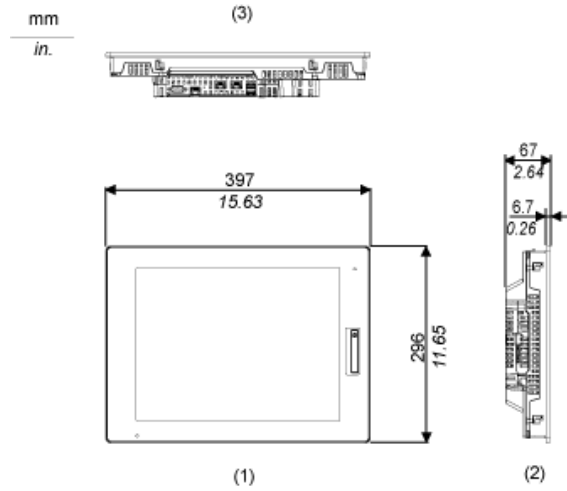

- 1 Front
- 2 Left
- 3 Bottom

Installation with Installation Fasteners and Dimensions with Cables

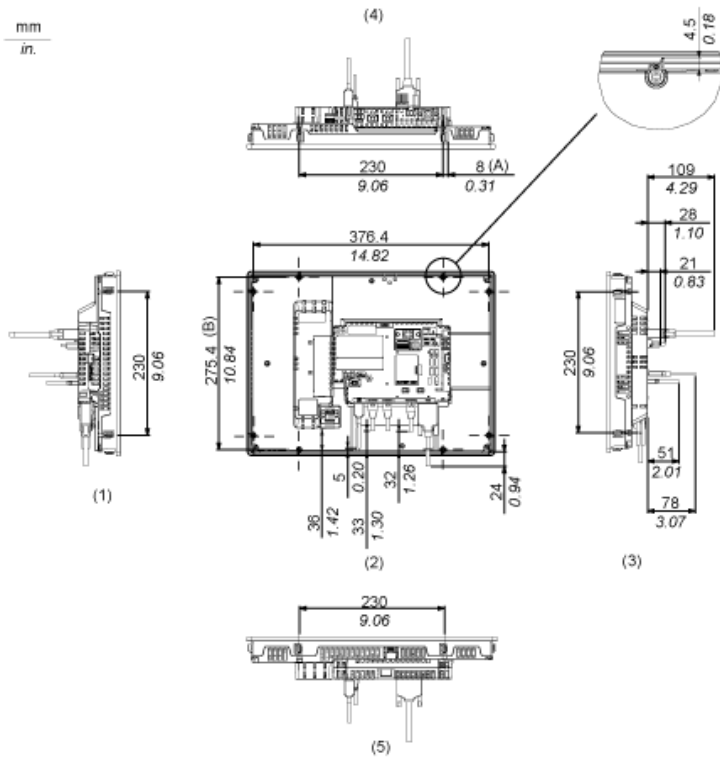

- (A) Rotation area of the fastener
 (B) Pitch of the center of installation fastner screws
 1 Right
 2 Front
 3 Left
 4 Bottom
 5 Top

Mounting

Panel Cut Dimensions

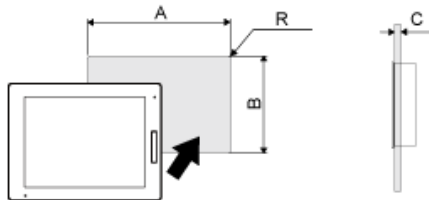

Dimensions in mm

A	B	C	R
383.5 (+1/-0)	282.5 (+1/-0)	1.6...5	3 max.

Dimensions in in.

A	B	C	R
15.10 (+0.04/-0)	11.12 (+0.04/-0)	0.06...0.2	0.12 max.

Installation Requirements

Mounting Angle

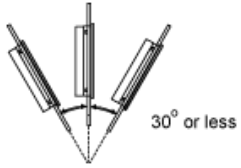

When installing this product in a slanted position with an incline more than 30°, the ambient temperature must not exceed 40 °C (104 °F). You may need to use forced air cooling (fan, A/C) to ensure the ambient operating temperature is 40 °C or less (104 °F or less).

Clearance

