



Main

Range of product	Modicon X80
Product or component type	Analog input module
Electrical connection	1 connector 28 ways
Input output isolation	Non isolated
Input level	High level
Analogue input number	8
Analogue input type	Current +/- 20 mA Current 0...20 mA Current 4...20 mA Voltage +/- 10 V Voltage +/- 5 V Voltage 0...10 V Voltage 0...5 V Voltage 1...5 V

Complementary

Analog/digital conversion	16 bits
Analogue input resolution	15 bits + sign
Input impedance	10 MOhm
Permitted overload on inputs	+/- 30 mA 0...20 mA +/- 30 mA 4...20 mA +/- 30 V +/- 10 V +/- 30 V +/- 5 V +/- 30 V 0...10 V +/- 30 V 0...5 V +/- 30 V 1...5 V +/- 30 mA +/- 20 mA
Internal conversion resistor	250 Ohm
Precision of internal conversion resistor	0.1 % - 15 ppm/°C
Type of filter	First order digital filtering
Fast read cycle time	1 ms + 1 ms x number of channels used
Nominal read cycle time	9 ms for 8 channels
Measurement error	<= 0.1 % of full scale +/- 10 V 0...60 °C <= 0.1 % of full scale +/- 5 V 0...60 °C <= 0.1 % of full scale 0...10 V 0...60 °C <= 0.1 % of full scale 0...5 V 0...60 °C <= 0.1 % of full scale 1...5 V 0...60 °C <= 0.3 % of full scale +/- 20 mA 0...60 °C <= 0.3 % of full scale 0...20 mA 0...60 °C <= 0.3 % of full scale 4...20 mA 0...60 °C 0.15 % of full scale +/- 20 mA 25 °C 0.15 % of full scale 0...20 mA 25 °C 0.15 % of full scale 4...20 mA 25 °C 0.08 % of full scale +/- 10 V 25 °C 0.08 % of full scale 0...10 V 25 °C 0.08 % of full scale 0...5 V 25 °C 0.08 % of full scale 1...5 V 25 °C 0.08 % of full scale +/- 5 V 25 °C <= 0.2 % of full scale +/- 10 V 0...60 °C
Temperature drift	30 ppm/°C 50 ppm/°C
Recalibration	Factory calibrated
Common mode between channels	>= 120 dB
Digital value format	+/- 10000 by default +/- 32000 in user scale
Isolation voltage	1400 V DC between channels and ground 1400 V DC between channels and bus

The information provided in this documentation contains general descriptions and/or technical characteristics of the performance of the products contained herein. This documentation is not intended as a substitute for and is not to be used for determining suitability or reliability of these products for specific user applications. It is the duty of any such user or integrator to perform the appropriate and complete risk analysis, evaluation and testing of the products with respect to the relevant specific application or use thereof. Neither Schneider Electric Industries SAS nor any of its affiliates or subsidiaries shall be responsible or liable for misuse of the information contained herein.

50 V DC between channels

Measurement resolution	0.36 mV +/- 10 V 0.36 mV 0...10 V 0.36 mV 0...5 V 0.36 mV 1...5 V 0.36 mV +/- 5 V 1.4 µA +/- 20 mA 1.4 µA 0...20 mA 1.4 µA 4...20 mA
Maximum conversion value	+/- 11.4 V +/- 10 V +/- 11.4 V 0...10 V +/- 11.4 V 0...5 V +/- 11.4 V 1...5 V 0...30 mA +/- 20 mA 0...30 mA 0...20 mA 0...30 mA 4...20 mA 0...30 mA +/- 5 V
Status LED	1 LED green RUN 1 LED per channel green channel diagnostic 1 LED red ERR 1 LED red I/O
Product weight	0.165 kg
Current consumption	30 mA at 24 V DC 150 mA at 3.3 V DC

Environment

vibration resistance	3 gn
shock resistance	30 gn
ambient air temperature for storage	-40...85 °C
ambient air temperature for operation	0...60 °C
relative humidity	5...95 % 55 °C without condensation
IP degree of protection	IP20
directives	2012/19/EU - WEEE directive 2014/30/EU - electromagnetic compatibility 2014/35/EU - low voltage directive
product certifications	CE CSA UL RCM Merchant Navy EAC
standards	EN 61000-6-2 EN 61000-6-4 EN 61131-2 EN 61010-2-201
protective treatment	TC
operating altitude	0...2000 m 2000...5000 m (with derating factor)

Offer Sustainability

Sustainable offer status	Green Premium product
RoHS (date code: YYWW)	Compliant - since 0901 - Schneider Electric declaration of conformity
REACH	Reference not containing SVHC above the threshold
Product environmental profile	Available
Product end of life instructions	Available

Contractual warranty

Warranty period	18 months
-----------------	-----------

Modules Mounted on Racks

Dimensions

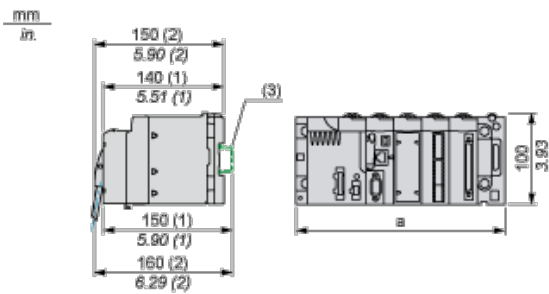

- (1) With removable terminal block (cage, screw or spring).
- (2) With FCN connector.
- (3) On AM1 ED rail: 35 mm wide, 15 mm deep. Only possible with BMXXBP0400/0400H/0600/0600H/0800/0800H rack.

Rack references	a in mm	a in in.
BMXXBP0400 and BMXXBP0400H	242.4	09.54
BMXXBP0600 and BMXXBP0600H	307.6	12.11
BMXXBP0800 and BMXXBP0800H	372.8	14.68
BMXXBP1200 and BMXXBP1200H	503.2	19.81

Wiring Diagram

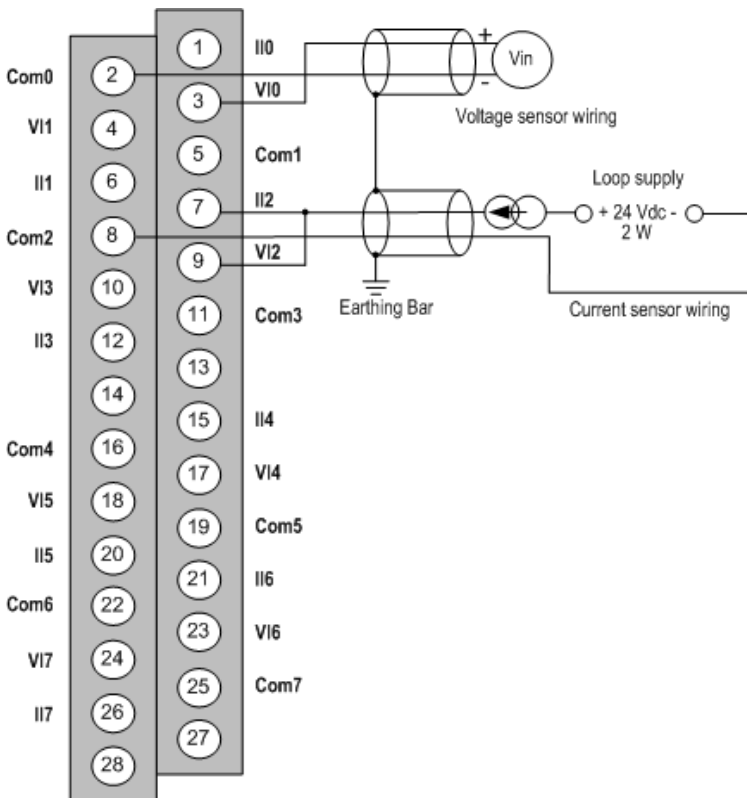

VIx + pole input for channel x.

COMx- pole input for channel x, COMx are connected together internally.

IIx current reading resistor + input.

Channelvoltage sensor.

0

Channel2-wire current sensor.

1