

# Product data sheet

Specifications



## variable speed drive, Easy Altivar 610, 15kW, 20hp, 380 to 460V, IP20

ATV610D15N4

### Main

Range of product	Easy Altivar 610
Product specific application	Fan, pump, compressor, conveyor
Product or component type	Variable speed drive
Device short name	ATV610
Variant	Standard version
Product destination	Asynchronous motors Synchronous motors
Mounting mode	Cabinet mount
EMC filter	Integrated conforming to IEC 61800-3 category C3 with 50 m
IP degree of protection	IP20
Type of cooling	Forced convection
Supply frequency	50...60 Hz +/-5 %
Network number of phases	3 phases
[Us] rated supply voltage	380...460 V - 15...10 %
Motor power kW	15 kW for normal duty 11 kW for heavy duty
Motor power hp	20 hp for normal duty 15 hp for heavy duty
Line current	29.4 A at 380 V (normal duty) 26.0 A at 460 V (normal duty) 23 A at 380 V (heavy duty) 20.8 A at 460 V (heavy duty)
Prospective line I <sub>sc</sub>	22 kA
Apparent power	20.7 kVA at 460 V (normal duty) 16.6 kVA at 460 V (heavy duty)
Continuous output current	31.7 A at 4 kHz for normal duty 23.5 A at 4 kHz for heavy duty
Maximum transient current	34.9 A during 60 s (normal duty) 35.3 A during 60 s (heavy duty)
Asynchronous motor control profile	Variable torque standard Optimized torque mode Constant torque standard
Output frequency	0.1...500 Hz
Nominal switching frequency	4 kHz
Switching frequency	2...12 kHz adjustable
number of preset speeds	16 preset speeds
Communication port protocol	Modbus serial

<b>Option card</b>	Slot A: communication card, Profibus DP V1 Slot A: digital or analog I/O extension card Slot A: relay output card
--------------------	---

## Complementary

<b>Output voltage</b>	<= power supply voltage
<b>Motor slip compensation</b>	Can be suppressed Not available in permanent magnet motor law Automatic whatever the load Adjustable
<b>Acceleration and deceleration ramps</b>	S, U or customized Linear adjustable separately from 0.01 to 9000 s
<b>Braking to standstill</b>	By DC injection
<b>Protection type</b>	Thermal protection: motor Motor phase break: motor Thermal protection: drive Overheating: drive Overcurrent between output phases and earth: drive Overload of output voltage: drive Short-circuit protection: drive Motor phase break: drive Overvoltages on the DC bus: drive Line supply overvoltage: drive Line supply undervoltage: drive Line supply phase loss: drive Overspeed: drive Break on the control circuit: drive
<b>Frequency resolution</b>	Display unit: 0.1 Hz Analog input: 0.012/50 Hz
<b>Electrical connection</b>	Control, screw terminal: 0.5...1.5 mm <sup>2</sup> Line side, screw terminal: 6...16 mm <sup>2</sup> Motor, screw terminal: 6...16 mm <sup>2</sup>
<b>Connector type</b>	1 RJ45 (on the remote graphic terminal) for Modbus serial
<b>Physical interface</b>	2-wire RS 485 for Modbus serial
<b>Transmission frame</b>	RTU for Modbus serial
<b>Transmission rate</b>	4.8, 9.6, 19.2, 38.4 kbit/s for Modbus serial
<b>Type of polarization</b>	No impedance for Modbus serial
<b>Number of addresses</b>	1...247 for Modbus serial
<b>Method of access</b>	Slave
<b>Supply</b>	External supply for digital inputs: 24 V DC (19...30 V), <1.25 mA, protection type: overload and short-circuit protection Internal supply for reference potentiometer (1 to 10 kOhm): 10.5 V DC +/- 5 %, <10 mA, protection type: overload and short-circuit protection
<b>Local signalling</b>	2 LEDs for local diagnostic 1 LED (yellow) for embedded communication status 2 LEDs (dual colour) for communication module status 1 LED (red) for presence of voltage
<b>Width</b>	171 mm
<b>Depth</b>	233 mm
<b>Product weight</b>	7.730 kg
<b>Analogue input number</b>	3
<b>Analogue input type</b>	AI1, AI2, AI3 software-configurable voltage: 0...10 V DC, impedance: 30 kOhm, resolution 12 bits AI1, AI2, AI3 software-configurable current: 0...20 mA, impedance: 250 Ohm, resolution 12 bits AI2, AI3 software-configurable temperature probe or water level sensor
<b>Discrete input number</b>	6

<b>Discrete input type</b>	DI1...DI6 programmable as logic input, 24 V DC ( $\leq 30$ V), impedance: 3.5 kOhm DI5, DI6 programmable as pulse input: 0...30 kHz, 24 V DC ( $\leq 30$ V)
<b>Input compatibility</b>	DI1...DI6: logic input level 1 PLC conforming to IEC 61131-2 DI5, DI6: pulse input level 1 PLC conforming to IEC 65A-68
<b>Discrete input logic</b>	Positive logic (source): DI1...DI6 configurable logic input, $< 5$ V (state 0), $> 11$ V (state 1) Negative logic (sink): DI1...DI6 configurable logic input, $> 16$ V (state 0), $< 10$ V (state 1) Positive logic (source): DI5, DI6 configurable pulse input, $< 0.6$ V (state 0), $> 2.5$ V (state 1)
<b>Analogue output number</b>	2
<b>Analogue output type</b>	Software-configurable current AQ1, AQ2: 0...20 mA, resolution 10 bits Software-configurable voltage AQ1, AQ2: 0...10 V DC impedance 470 Ohm, resolution 10 bits
<b>Sampling duration</b>	5 ms $\pm$ 0.1 ms (AI1, AI2, AI3) - analog input 2 ms $\pm$ 0.5 ms (DI1...DI6)configurable - discrete input 5 ms $\pm$ 1 ms (DI5, DI6)configurable - pulse input 10 ms $\pm$ 1 ms (AQ1, AQ2) - analog output
<b>Accuracy</b>	$\pm$ 0.6 % AI1, AI2, AI3 for a temperature variation 60 °C analog input $\pm$ 1 % AQ1, AQ2 for a temperature variation 60 °C analog output
<b>Linearity error</b>	AI1, AI2, AI3: $\pm$ 0.15 % of maximum value for analog input AQ1, AQ2: $\pm$ 0.2 % for analog output
<b>Relay output number</b>	3
<b>Relay output type</b>	Configurable relay logic R1: fault relay NO/NC electrical durability 100000 cycles Configurable relay logic R2: sequence relay NO electrical durability 100000 cycles Configurable relay logic R3: sequence relay NO electrical durability 100000 cycles
<b>Refresh time</b>	Relay output (R1, R2, R3): 5 ms ( $\pm$ 0.5 ms)
<b>Minimum switching current</b>	Relay output R1, R2, R3: 5 mA at 24 V DC
<b>Maximum switching current</b>	Relay output R1, R2, R3 on resistive load, $\cos \phi = 1$ : 3 A at 250 V AC Relay output R1, R2, R3 on resistive load, $\cos \phi = 1$ : 3 A at 30 V DC Relay output R1, R2, R3 on inductive load, $\cos \phi = 0.4$ and L/R = 7 ms: 2 A at 250 V AC Relay output R1, R2, R3 on inductive load, $\cos \phi = 0.4$ and L/R = 7 ms: 2 A at 30 V DC
<b>Isolation</b>	Between power and control terminals
<b>Insulation resistance</b>	$> 1$ MOhm 500 V DC for 1 minute to earth

## Environment

<b>Noise level</b>	65 dB conforming to 86/188/EEC
<b>Power dissipation in W</b>	408 W(forced convection) at 380 V, switching frequency 4 kHz 62 W(natural convection) at 380 V, switching frequency 4 kHz
<b>Operating position</b>	Vertical $\pm$ 10 degree
<b>Electromagnetic compatibility</b>	Electrostatic discharge immunity test level 3 conforming to IEC 61000-4-2 Radiated radio-frequency electromagnetic field immunity test level 3 conforming to IEC 61000-4-3 Electrical fast transient/burst immunity test level 4 conforming to IEC 61000-4-4 1.2/50 $\mu$ s - 8/20 $\mu$ s surge immunity test level 3 conforming to IEC 61000-4-5 Conducted radio-frequency immunity test level 3 conforming to IEC 61000-4-6
<b>Pollution degree</b>	2 conforming to IEC 61800-5-1
<b>Vibration resistance</b>	1.5 mm peak to peak ( $f = 2...13$ Hz) conforming to IEC 60068-2-6 1 gn ( $f = 13...200$ Hz) conforming to IEC 60068-2-6
<b>Shock resistance</b>	15 gn for 11 ms conforming to IEC 60068-2-27
<b>Relative humidity</b>	5...95 % without condensation conforming to IEC 60068-2-3
<b>Ambient air temperature for operation</b>	-15...45 °C (without derating) 45...60 °C (with derating factor)

<b>Operating altitude</b>	<= 1000 m without derating 1000...4800 m with current derating 1 % per 100 m
<b>Environmental characteristic</b>	Chemical pollution resistance class 3C3 conforming to IEC 60721-3-3 Dust pollution resistance class 3S3 conforming to IEC 60721-3-3
<b>Standards</b>	IEC 61800-3 Environment 2 category C3 IEC 61800-3 IEC 61800-5-1 IEC 60721-3
<b>Marking</b>	CE

## Packing Units

<b>Unit Type of Package 1</b>	PCE
<b>Number of Units in Package 1</b>	1
<b>Package 1 Height</b>	21.500 cm
<b>Package 1 Width</b>	34.500 cm
<b>Package 1 Length</b>	58.000 cm
<b>Package 1 Weight</b>	10.120 kg
<b>Unit Type of Package 2</b>	P06
<b>Number of Units in Package 2</b>	3
<b>Package 2 Height</b>	75.000 cm
<b>Package 2 Width</b>	60.000 cm
<b>Package 2 Length</b>	80.000 cm
<b>Package 2 Weight</b>	38.360 kg

## Contractual warranty

<b>Warranty (in months)</b>	18
-----------------------------	----



## Environmental Data

Schneider Electric aims to achieve Net Zero status by 2050 through supply chain partnerships, lower impact materials, and circularity via our ongoing “Use Better, Use Longer, Use Again” campaign to extend product lifetimes and recyclability.

[Environmental Data explained >](#)

[How we assess product sustainability >](#)



### Environmental footprint

Total lifecycle Carbon footprint	34 654 kg CO2 eq.
Carbon footprint of the manufacturing phase [A1 to A3]	886 kg CO2 eq.
Carbon footprint of the distribution phase [A4]	1 kg CO2 eq.
Carbon footprint of the installation phase [A5]	0.1 kg CO2 eq.
Carbon footprint of the use phase [B2, B3, B4, B6]	33 764 kg CO2 eq.
Carbon footprint of the end-of-life phase [C1 to C4]	2 kg CO2 eq.
Environmental Disclosure	<a href="#">Product Environmental Profile</a>

## Use Better



### Materials and Substances

Packaging made with recycled cardboard	No
Packaging without single use plastic	No
EU RoHS Directive	<a href="#">Compliant By Exemption</a>
REACH Regulation	<a href="#">Reference contains Substances of Very High Concern above the threshold</a>
California proposition 65	<b>WARNING:</b> This product can expose you to chemicals including: Lead and lead compounds, which is known to the State of California to cause cancer and birth defects or other reproductive harm. For more information go to <a href="http://www.P65Warnings.ca.gov">www.P65Warnings.ca.gov</a>



### Energy efficiency

Product contributes to saved and avoided emissions	Yes
--	-----

## Use Longer



### Lifetime extension

Repair	No
Updatability	Yes

## Use Again



### Repack and remanufacture

End of life manual availability	<a href="#">End of Life Information</a>
Take-back	No
WEEE Label	 The product must be disposed on European Union markets following specific waste collection and never end up in rubbish bins

Dimensions Drawings

Dimensions

---

IP20 Drives

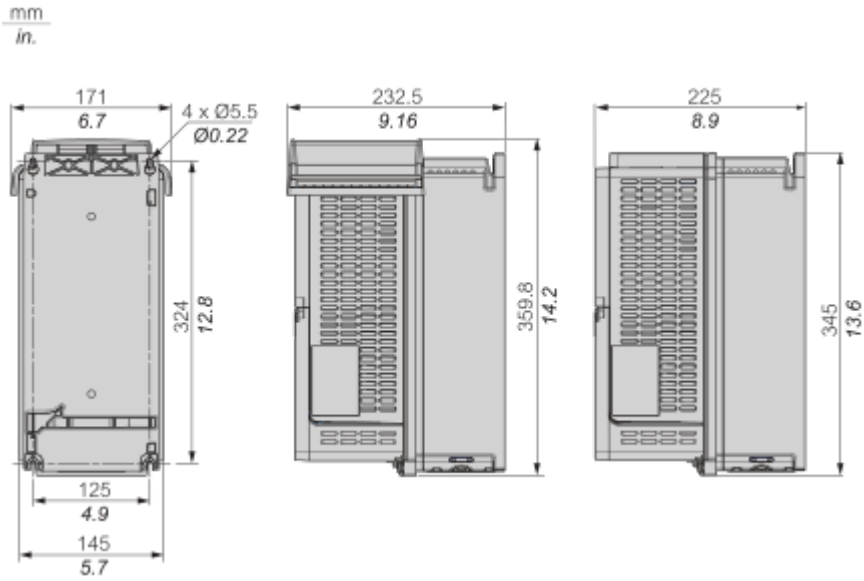

Drawings from left to right: rear view, right side view with top cover, right side view without top cover.

IP20 Drives With EMC Plate

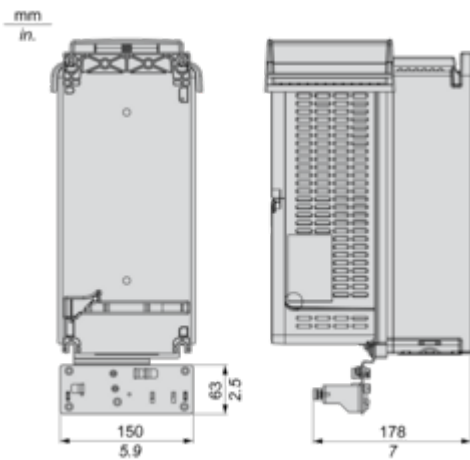

Drawings from left to right: rear view, right side view with top cover.

Mounting and Clearance

Clearances and Mounting Position - Wall Mounting

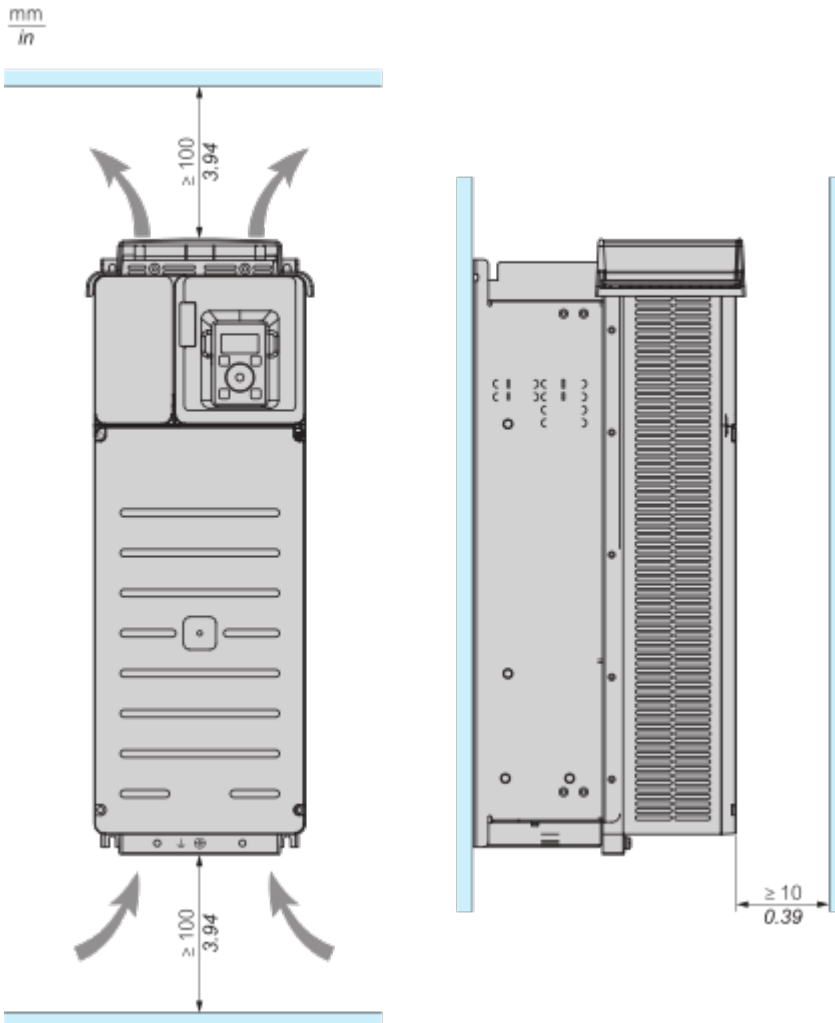

- Mount the device in a vertical position. This is required for cooling the device.
- Attach it on the mounting surface in compliance with standards, using 4 screws with captive washer.
- The use of washers is required with all mounting screws.
- Tighten the fixation screws.
- Do not mount the device close to heat sources.
- Avoid environmental effects like high temperatures and high humidity as well as dust, dirt and conductive gases.
- Adhere to the minimum installation distances for required cooling.
- Do not mount the device on flammable materials.

**Mounting Types**

---

**Mounting Type A: Individual IP21**

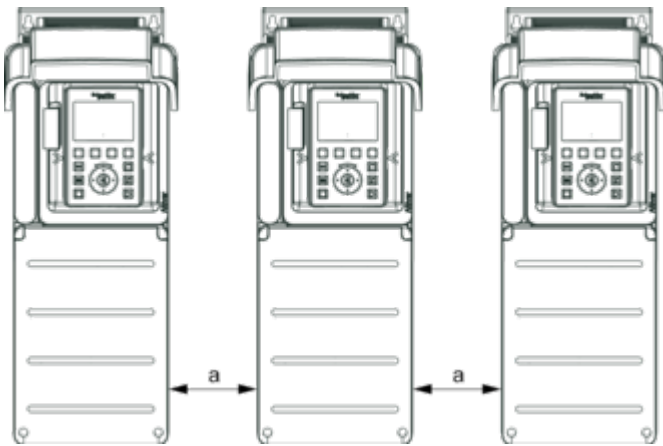

$a \geq 100 \text{ mm (3.94 in.)}$

**Mounting Type B: Side by Side IP20**

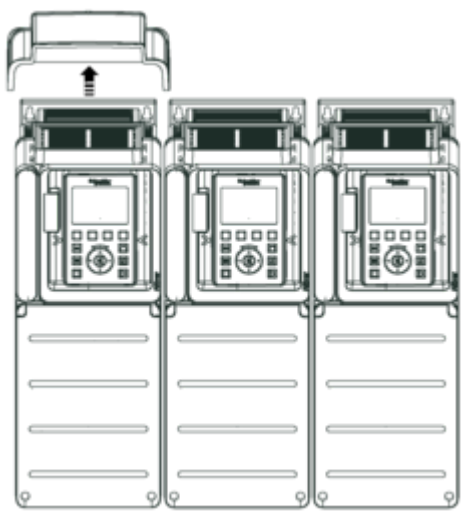

Connections and Schema

Three-phase Power Supply - Diagram With Line Contactor

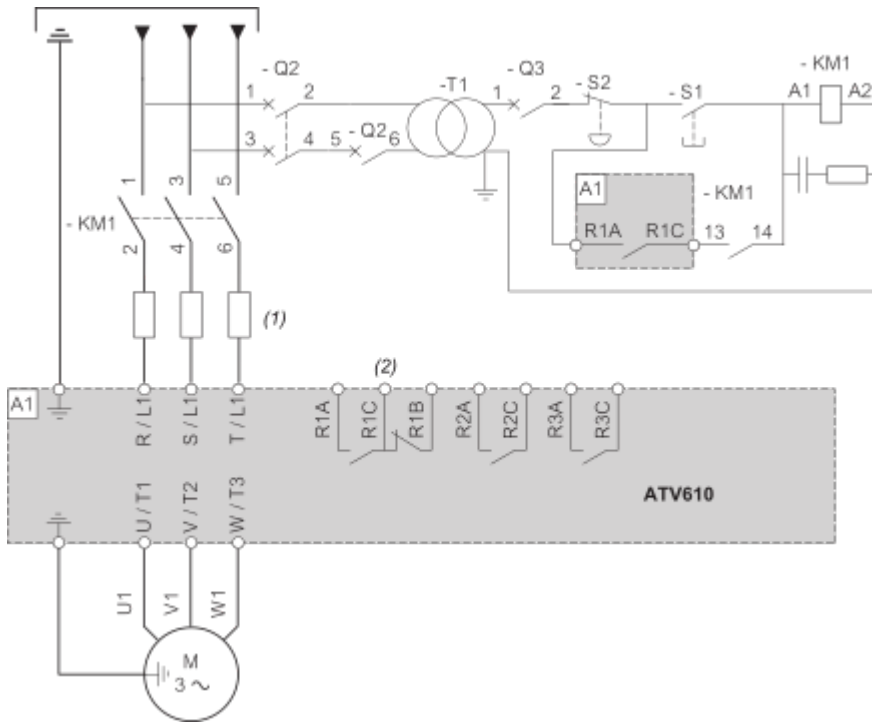

(1) Line choke (if used).

(2) Use relay output R1 set to operating state Fault to switch Off the product once an error is detected.

Control Block Wiring Diagram

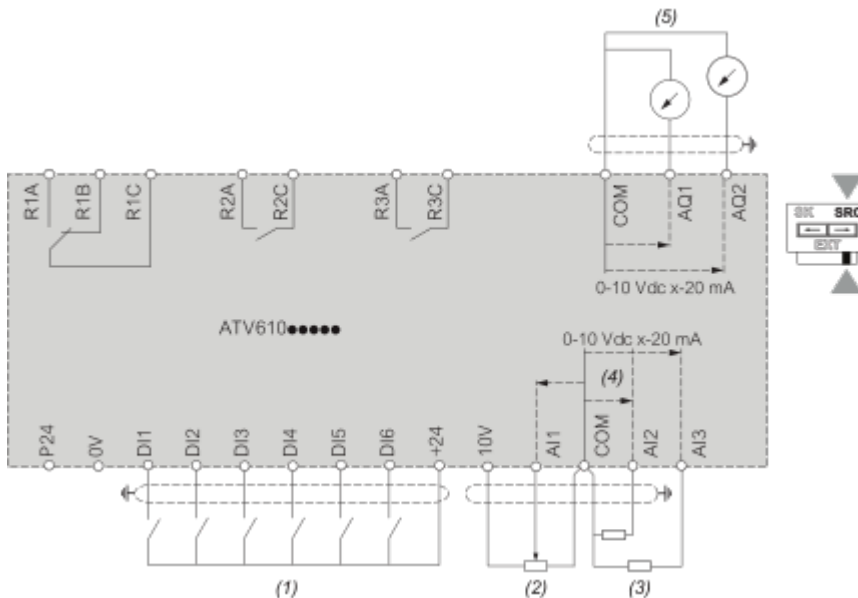

(1) : Digital Inputs

(2) : Reference potentiometer

(3) : Analog inputs

(4) : -10...+10 Vdc

(5) : Analog outputs

Sensor Connection

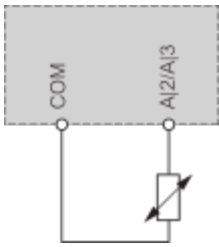

It is possible to connect either 1 sensors on terminals AI2 or AI3.

Performance Curves

Derating Curves

---

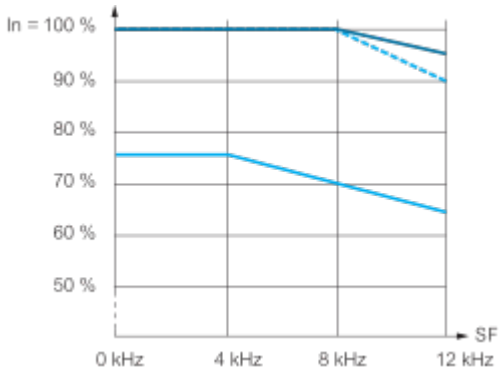

- 40 °C (104 °F) - Mounting type A, B and C
  - - - 45 °C (113 °F) - Mounting type A, B and C
  - 60 °C (140 °F) - Mounting type B and C
- In : Nominal Drive Current  
SF : Switching Frequency

Technical Illustration

Dimensions

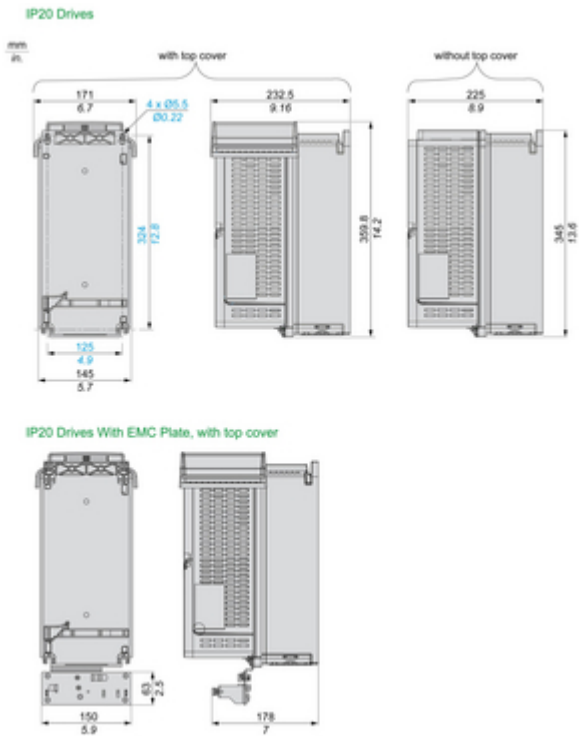

Technical Illustration

Wiring diagram

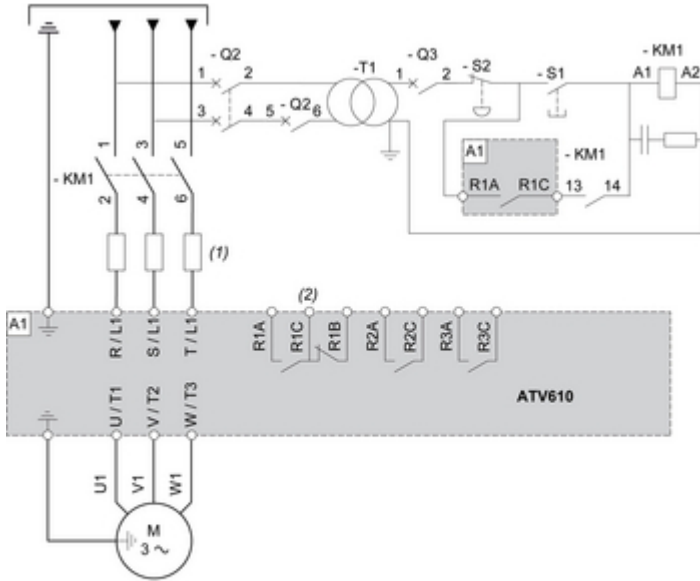

- (1) Line choke (if used).
- (2) Use relay output R1 set to operating state Fault to switch Off the product once an error is detected.